

3-Phase Induction Motor Drive with PWM Modulator Using A 8-Bit Low Cost Microcontroller

E. Kucukguzel, O. Bilgic

R&D Department, Tola Elektronik Ltd., Istanbul, Turkey
Hasanpaşa Mah, Uzunçayır Cad, No:39 C1 Blok D:11, Kadıköy, İst., Turkey, phone: (+90216) 3402255
e-mail: ekucukguzel@tola.com.tr
Faculty of Electrical and Electronics Engineering, Yıldız Technical University, Istanbul, Turkey
Yıldız Kampusu, 80750, Besiktas, Istanbul, Turkey, phone: (+90212) 2611998, fax: (+90212) 2594967
e-mail: bilgic@yildiz.edu.tr

Abstract— This paper describes a study on a well studied subject, driving 3-phase induction motor. But the hardware used for the study is different than the conventional 16-bit microcontrollers or DSPs. The aim of the project is to lower the price of control hardware and achieve a satisfying performance with less expensive 8-bit microcontrollers.

I. INTRODUCTION

Control of induction motor with sinusoidal PWM signals is widely used. When it comes to driving a 3-phase induction motor, even though the resultant PWM parameters can be 8-bits, the calculations need the precision of 16-bit arithmetics. This makes the achievement of satisfying resolution (better sinusoids, less harmonics, less noise) possible, even for low speeds. These requirements often need the performance of DSPs or 16-bit microcontrollers (MCUs) with hardware multiplier in them.

Here, a system with an 8-bit MCU is introduced. The aim of the study is to show that, if enough care is taken with the arithmetic operations implemented in the calculation algorithms, new generation 8-bit MCUs can perform 16 bit operations fast enough for a 3-phase PWM modulator and a control algorithm. This means replacement of more expensive hardware for many applications. With the fast RISC architecture of ATMEL AVR family AT90S8535 MCU (which can now be replaced with newer ATmega16 series), this study has been possible, as an example of low cost induction motor drive, which has a comparable performance to the more expensive systems.

II. ALGORITHM

In the calculations of the PWM modulator, operations should be as fast as possible and must be at 16-bit resolution. Special care is taken about the methods given below:

- Redundant multiplications or divisions should be avoided since they are the most time-consuming operations in a microprocessor.

- Multiplication and division operations should be replaced with other methods, where possible.
- For higher resolutions, saving n times the actual value of a variable is much better for operations (\log_2^n is an integer, $n \geq 2$).

With these conditions, θ , the stator rotating field angle is updated every PWM cycle with an operation like integration, then phase angles are obtained. To produce switching times of channels, a trigonometric function is stored in a look-up table (LUT). This trigonometric function gives the cosine of the angle with an additional third harmonic. It is shown that this additional harmonic helps amplifying the amplitude of the fundamental by 15.5% [1].

In order to generate sinusoidal signals with PWM, angle that varies with a speed proportional to the desired speed is to be calculated. Cosine of this angle is used to determine the duty cycle of the PWM signal, so a sinusoidal signal is obtained at the output with a frequency much smaller than the fixed PWM frequency. The angle is calculated and updated as follows :

$\Delta\theta$, is calculated according to the speed in every period of the PWM square wave and the angle is updated as

$$\theta_{\text{new}} = \theta_{\text{old}} + \Delta\theta \quad (1)$$

For precision, 128 times the actual values of θ and $\Delta\theta$ are stored. This increases resolution of the addition which is needed for angle update. Considering the speed (SPD variable) as tours per minute, resultant $\Delta\theta$ is given by:

$$\Delta\theta = \text{SPD} \times 10 / (\text{F_INT1} / 32) \quad (2)$$

where F_INT1 is PWM timer interrupt frequency of the microcontroller, and the denominator is a constant that is precalculated.

θ is used for precise additions. To calculate cosines of three phases, we divide θ by 128 to get $\alpha_U, \alpha_V, \alpha_W$ which have a full angle of 150 units ($0 \dots 360^\circ$ corresponds to $0 \dots 150$ unit angles)

So the angle differences between phases are $150 / 3 = 50$ units.

$$\alpha_U = \theta / 128, \alpha_V = \alpha_U + 50, \alpha_W = \alpha_V + 50 \quad (3)$$

Angle resolution of 150 units is chosen for the ease of calculation and for limiting the variable in a byte length. Cosine values are calculated from a look up table (LUT) stored in the program memory, where all the 150 cosine values of angles are mapped, to produce COS_U, COS_V, COS_W (cosine of phase angles). In the end, PWM_U, PWM_V, PWM_W values are calculated as below, and written to the dedicated PWM registers:

$$PWM_U = \underbrace{\underbrace{(VMAX \times COS_U / 100)}_{16\text{-bit signed}}}_{8\text{-bit signed}} + 128 \quad (4)$$

8-bit unsigned

These parameters give the duty cycles, that is, the durations that power MOSFETs are in on-state.

III. HARDWARE

The system designed for this study consists of a Control Unit, a MOSFET Drive Unit and a Power Supply Unit. Only the control unit is our focus, others are not.

The control unit contains AT90S8535 AVR family MCU from ATMEL, user interface parts (LC display and keys), PC interface (RS232 converter), physical interfaces for; analog inputs, In System Programming port, RS232 and PWM outputs (Fig.1 and Fig.4).

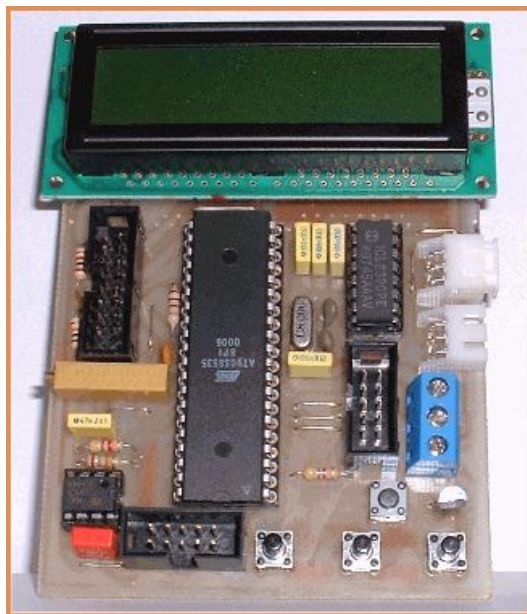

Figure 1. A photo of the control unit

The key features of the MCU, about the subject, are :

- AVR MCUs implement most instructions at 1 clock cycle[2]. This is a very important factor for fast calculations.
- AT90S8535 model has three PWM channels, the system requires no external modulator hardware.

- Eight channels of 10-bit ADC can be used for the feedback of currents or voltages for the desired control algorithm.
- Integrated UART (Universal Asynchronous Receive Transmit) peripheral establishes serial communications with PC or other controllers, for monitoring and control purposes.
- In System Programmable FLASH program memory of the MCU makes software updates and new algorithms possible.
- The MCU has no hardware multiplier, divider.

The MOSFET drive unit receives three channels of PWM signals, generates six signals for the six MOSFET switches. Feedback from the DC link current and a phase voltage are the analog outputs of the unit to the control unit. All signalling between the two units are done via optical isolation. The most important component of the circuit (Fig.6) is the IR2130, the three-phase bridge driver (IC3). To drive six power MOSFETs, three signals are enough. These signals come from the control card and applied to the HIN1, HIN2, HIN3 inputs of IC3. LIN1, LIN2, LIN3, signals are obtained by logically inverting these HIN signals with logic inverter 7404 (IC2).

The drive unit is absolutely isolated from the control card for overvoltage protection. Optocouplers TLP620 (IC1) and 6N135 (IC5, IC6) establishes 5000V_{RMS} and 2500V_{RMS} isolation respectively.

Input of the power supply unit is the 220 V_{RMS} means voltage through K1 connector (Fig.5). Three voltage outputs are generated in the unit :

- High DC Voltage (nearly equal to the peak voltage of the input, measured as 305 V.)
- 15 VDC.
- 5 VDC.

First two is for the drive card and the last one is for the control card.

The control unit has RS232 interface for communication purposes. A PC program can take the speed control, the user interface stuff as well as the system can operate in stand-alone mode.

A simple PC program is written just as a remote user interface. Measured voltage, current and speed is transferred to the PC when desired speed, start and stop commands are sent to the system from the PC.

IV. RESULTS

In experimental work, a three-phase squirrel cage induction motor (SCIM) of 250W has been driven successfully.

Current measurements are made at a single phase (Fig.2 and Fig.3)

The carrier frequency is about 2 KHz when pulse widths (switching times) are updated in one carrier and it is 8 KHz if switching times are updated in four carrier periods as in [3].

PWM resolution is $1/256$.

Output frequency range is between 0.12 Hz and 100 Hz with a resolution of 1 rpm which is equivalent to 0.0160 Hz.

These parameters guarantee smooth operation even at low speeds. And also are comparable with the performance of systems with 16-bit MCUs in [4]-[5].

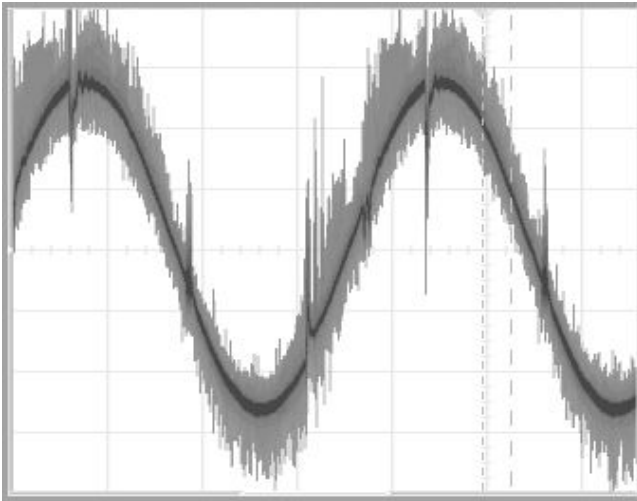

Figure 2. Current measured on a single phase

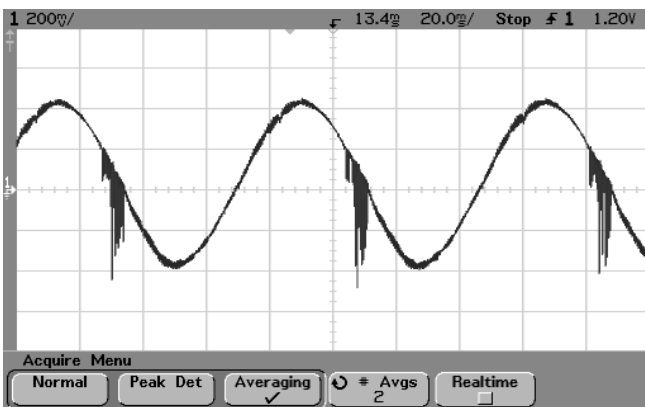

Figure 3. Current, measured and filtered with the averaging function of the scope, on a single phase

V. CONCLUSION

An acceptable performance for many applications can be achieved with a new generation 8-bit microcontroller, close to that of 16-bit systems, when there is need for 3-phase SCIM speed control. This fact reduces the cost of the system, increasing the software complexity. The selected MCU is in-system re-programmable, that is, the algorithm can be updated easily. PC connection helps the user monitor parameters.

REFERENCES

- [1] Houldsworth J.A., Grant D.A., "The Use of Harmonic Distortion to Increase the Output of a Three-Phase PWM Inverter", *IEEE Trans. on Industry Applications*, vol.IA-20, no.5, 1984.
- [2] ATMEL Corporation, "AVR Enhanced RISC Microcontroller Databook", 2000.
- [3] Minas G., Martins J.S., Couto C., "A microcontroller based voltage space vector modulator suitable for induction motor drives", *International Symposium on Industrial Electronics (ISIE '99)*, vol.2, pp 469-473, 12-16 July 1999, Bled, Slovenia.
- [4] Chunting Mi, Shen J., Natarajar N., "Field-oriented control of induction motors based on a MC68322 microcontroller", *The 7th IEEE Workshop on Power Electronics in Transportation (WPET 2002)*, pp.69-73, October 24-25 2002, Michigan, USA.
- [5] Yiliang T., Wenjin C., Xiaorong X., Yingduo H., Wong M., "80C196MC microcontroller-based inverter motor control and IR2130 six-output IGBT driver", *International Conference on Electric Machines and Drives (IEMD '99)*, pp.655-657, 9-12 May 1999, Seattle, USA.

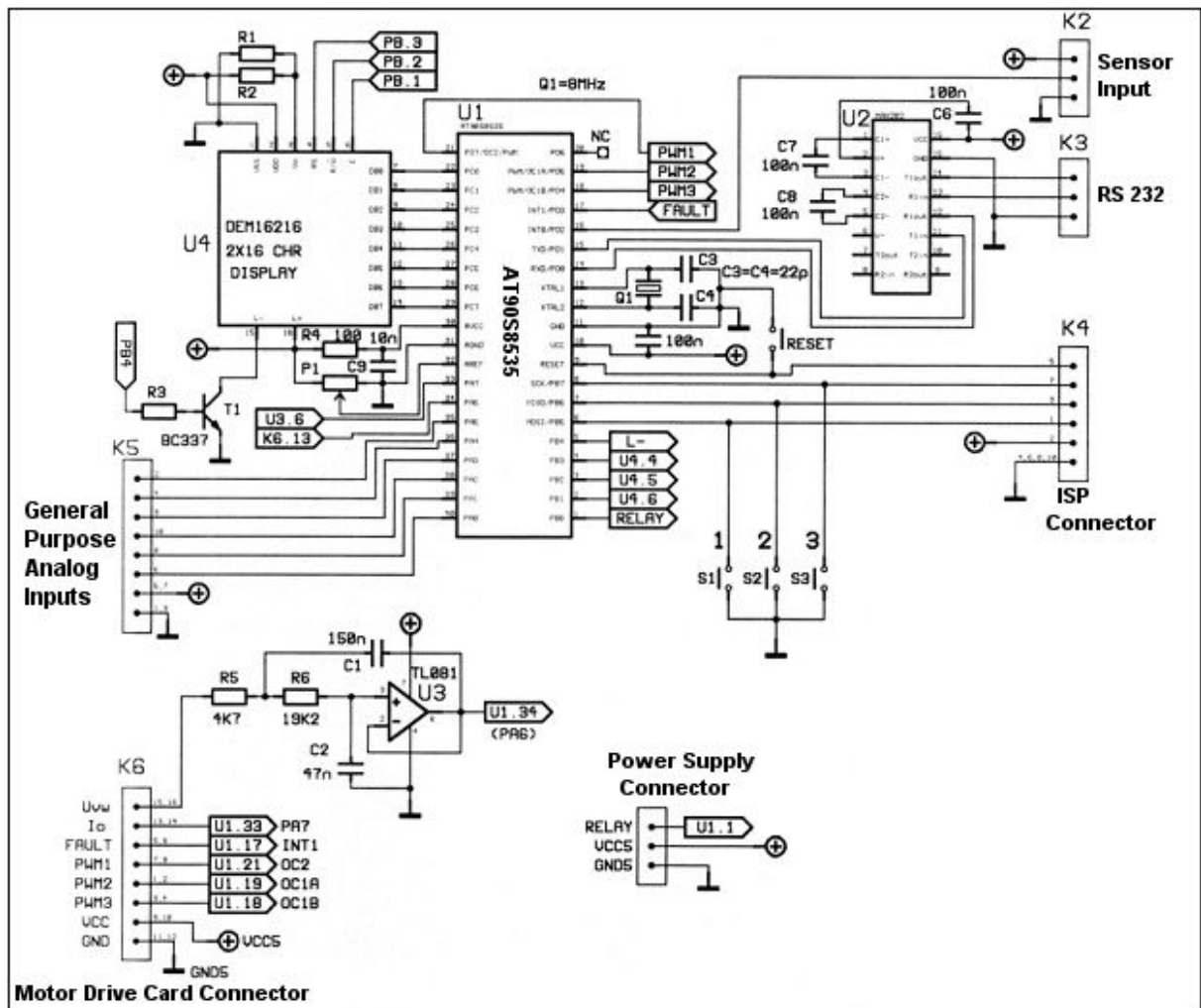

Figure 4. Control Unit

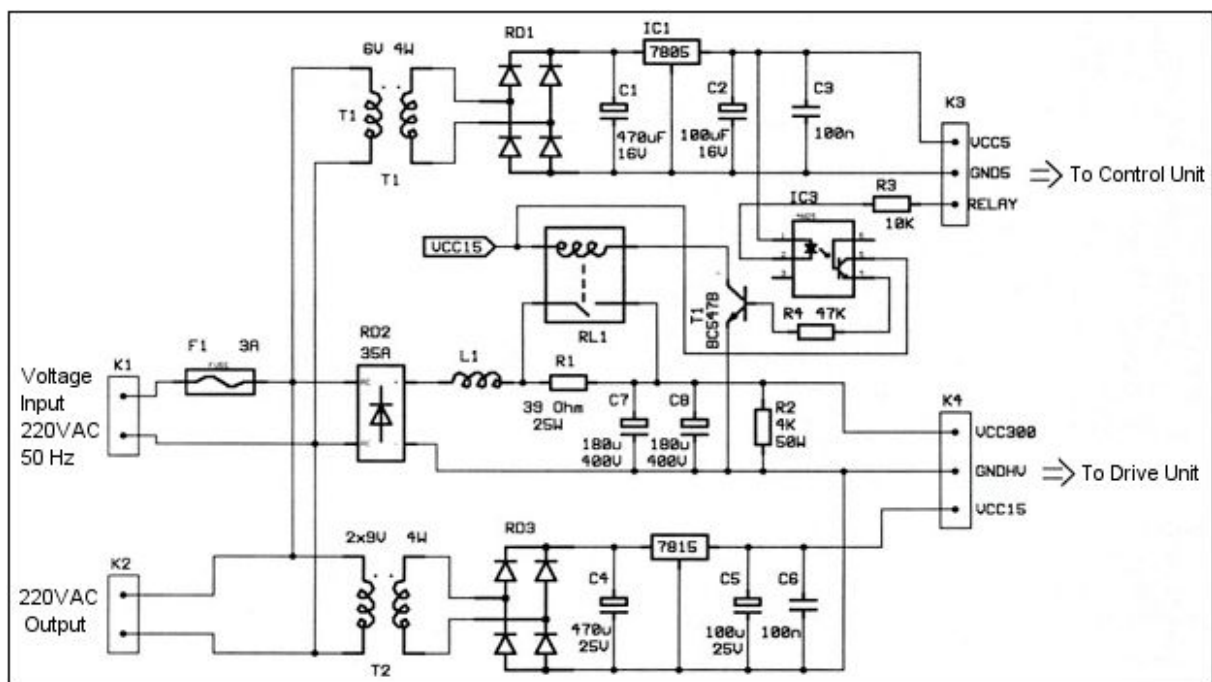

Figure 5. Power Supply Unit

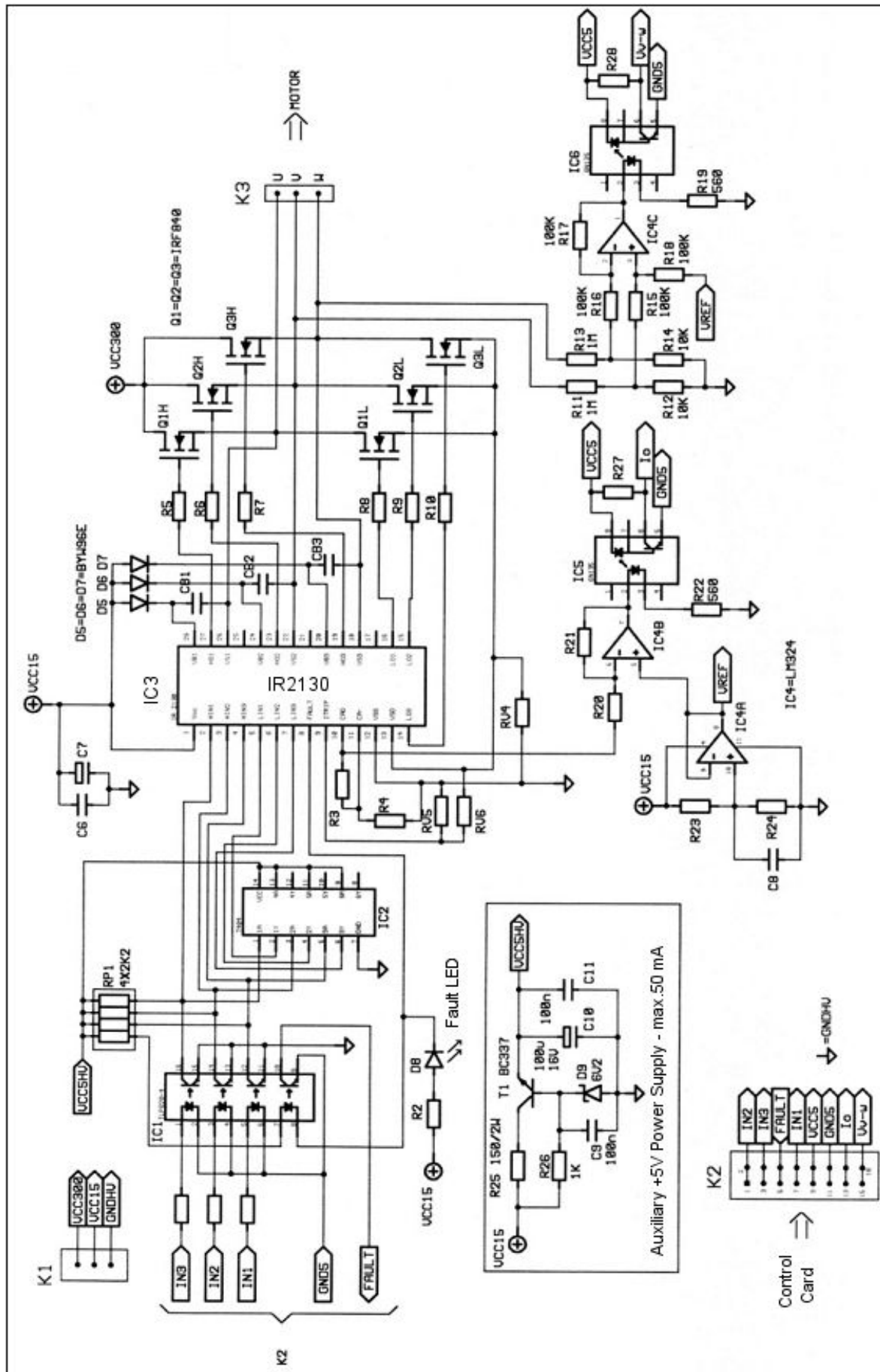

Figure 6. MOSFET Drive Unit